



MAC060-03-L Air-Cooled Chiller

Air-Cooled Chillers for Global
Residential and Light Commercial
Micro Climates

HVAC Guide Specifications

Air-Cooled Liquid Chiller with Low Ambient Kit

Nominal Size:

5 Tons

MultiAqua Model Number:

MAC060-03-L

Part 1-General

1.01 System Description

MultiAqua air-cooled liquid chillers are designed using scroll compressors, low sound condenser fans and high efficiency pumps.

1.02 Quality Assurance

- A. Certified in accordance with U.L. Standard 95, latest version (U.S.A.).
- B. Construction shall comply with ASHRAE 15 Safety Code, NEC and ASME applicable codes. (U.S.A. Codes).
- C. Manufactured in a facility registered to ISO 9002, Manufacturing Quality Standard.
- D. ETL Certified
- E. Fully load tested at the factory.
- F. Damage resistant packaging.

1.03 Delivery, Storage and Handling

- A. Packaged and readied for shipment from the factory.
- B. Controls shall be capable of withstanding 150°F storage temperatures in the control compartment.
- C. Stored and handled per manufacturer's recommendations.

Part 2-Product

2.01 Equipment

- A. General:
 1. Unit shall be a factory assembled and tested air-cooled liquid chiller.
 2. Shall be assembled on heavy gauge steel mounting/lifting rails.
 3. Contained within the unit cabinet shall be all factory wiring, piping, controls, refrigerant charge (R407c), POE oil and special accessories required prior to start up.
 4. Brass body strainer with 20 mesh screen and blow down shall be supplied in cabinet as a field installable accessory.
- B. Unit Cabinet:
 1. Composed of heavy gauge galvanized steel casing with a baked polyester powder.
 2. Capable of withstanding 500-hour salt spray test in accordance with the ASTM (USA) standard.
- C. Condenser Fans:
 1. 4-blade, aluminum construction and shall be dynamically balanced and corrosion resistant.
 2. Horizontal discharged air.
 3. Motors and blades shall be protected by coated steel wire safety guards.
- D. Fan Motors:
 1. Condenser fan motors shall be single speed, direct drive.
 2. Totally enclosed.
 3. Permanently lubricated sleeve bearings and Class F insulation.
 4. Internal overload protection.
- E. Compressors:
 1. Unit shall contain one fully hermetic scroll compressors.
 2. Direct-drive, 3500 rpm (60Hz)
 3. Compressor motor shall be suction gas cooled.
 4. Internal motor protection.
 5. Externally protected by low and high pressure cutout devices.
 6. Individual vibration isolators.

F. Pump:

1. Integral circulating pump shall be stainless steel with high efficiency enclosed motor.
2. Unit shall have chilled liquid solution piping to the exterior of the cabinet.

G. Evaporator:

1. Evaporator shall have one independent refrigerant circuit and one liquid solution circuit.
2. Rated for a refrigerant side working pressure of 450 psig and a maximum water side working pressure of 60 psig.
3. Single pass, ANSI type 316 stainless steel, brazed plate construction.
4. Externally insulated with closed cell, elastomeric foam. (ASTM518)

H. Condenser:

1. Condenser coil shall be air-cooled with integral sub-cooler.
2. One independent refrigerant circuit.
3. Constructed of rifled copper tubing mechanically bonded to aluminum fins.
4. Cleaned and dehydrated.
5. Factory leak tested to 450 psig.

I. Refrigerant Circuits:

1. Each circuit shall contain a sight glass, liquid line filter, thermal expansion valve, refrigerant charge of R407c and POE compressor oil.

Part 3-Controls and Safeties**3.01 Controls**

- A. Chiller shall be completely factory wired and tested.
- B. Temperature control shall be based on leaving chilled liquid solution temperature.
 1. Temperature accuracy shall be + - 1
- C. Controls shall include the following components.
 1. 24vac transformer to serve all controllers relays and control components.
 2. Microprocessor based liquid solution temperature controller.
 3. Leaving water temperature thermistor.
 4. Pump bypass timer.
 5. Compressor recycle timer.
 6. Optional low pressure bypass timer for low ambient operation.
 7. Optional fan cycling control for low ambient operation.
 8. Chilled liquid solution flow switch.

3.02 Safeties

- A. Unit shall be equipped with thermistors and all necessary components in conjunction with the control system to provide the following protectants.
 1. Low refrigerant pressure.
 2. High refrigerant pressure.
 3. Low chilled liquid solution temperature.
 4. Low chilled liquid solution flow.
 5. Thermal overload.
 6. Short cycling.

Part 4-Operating Characteristics:**4.01 Temperatures**

- A. Unit shall be capable of starting and running at outdoor temperatures from 55°F to 120°F.
- B. Optional Low Ambient Kit shall allow starting and running at outdoor temperatures to -20°F. A field supplied and installed crankcase heater must be used when operating at these temperatures.
- C. Unit shall be capable of starting up with a maximum 80°F and a sustained 70°F entering fluid solution temperature to the evaporator.
- C. Minimum 10% Glycol solution is always required.
- D. For outdoor temperatures below 32°F, reference MAC Glycol Solution Data table.

4.02 Electrical Requirements

- A. Primary electrical power supply shall enter the unit at a single location.
- B. Electrical power supply shall be rated to withstand 120°F operating ambient temperature.
- C. Units shall be available in 1 or 3-phase power at the voltages shown in the equipment electrical data.
- D. Control points shall be accessed through terminal block.

Part 5- Definitions:**5.01 Abbreviations**

- A. CFM = Cubic Feet per Minute
- B. DB = Dry Bulb Temperature
- C. EWT = Entering Water Temperature
- D. GPM = US Gallons Per Minute
- E. MBH = BTU X 1000
- F. SC = Sensible Cooling
- G. TC = Total Cooling = Sensible + Latent
- H. WB = Wet Bulb Temperature
- I. WPD = Water Pressure Drop in feet of head
- J. dB = Decibel Level
- K. m = Meter

5.02 Measurements

- A. All measurements with regard to length, width, and height shall be in inches.

MAC060-03-L Product Specifications

Physical Data										
Model Number	Coil				Chiller				Weight (lbs.)	
	Height (in)	Length (in)	Copper Diameter (in)	Coil Rows	Height (in)	Length (in)	Width (in)	Refrigerant R407c	Net	Shipping
MAC060-03-L	38	48	3/8	2	49.75	39.75	16.25	88.00 oz.	313	316

Model Number	Volts/ Phase/ Hertz	Compressor		Condenser Fan Motor (2 Qty)		Pump Motor		Fuse or HACR Circuit Breaker Per Circuit	
		(RLA)	(LRA)	(FLA)	(RPM)	(FLA)	(RPM)	MCA	MOP
MAC060-03-L	380-460-3-50/60	10	75	.60	1050	2.85	3500	16.55	25

	MAC060-03-L
Compressor	Copeland Scroll
Refrigerant	R407c
Heat Exchanger	Brazed Plate
Max. Pump Head Pressure	50 ft.
Max Flow Rate	14.4 gpm
Min Flow Rate	6.5 gpm
Supply Water Temp	44°
Return Water Temp	54°
Min. Solution Content	25 Gallons
Expansion Tank Size	2 Gallons
Pump*	0.5 HP
Water Connections	1" S & 1.25" R
Internal Pressure loss	1.68 ft. of head

*Internal Pump Included

MultiAqua chillers are designed to operate exclusively with R407c refrigerant in a self-contained, pre-charged refrigerant system. Do not access the closed refrigerant circuit for any reason other than after-sale, after installation component replacement. Routine maintenance and service is to be performed by qualified personnel only.

MAC060-03-L Product Specifications

MAC060-03-L Capacity / Watts / EER / COP*				
O/A Temp (°F)	Tons	KW	EER	COP
82	5.1	5.3	11.55	3.38
95	4.9	5.9	9.97	2.92
100	4.8	6.1	9.44	2.76
105	4.7	6.4	8.81	2.58
110	4.7	6.5	8.68	2.54

* The following equation was used to calculate COP values other than ARI conditions: COP = EER x .2928

Glycol Solution Data				
Propylene Glycol %	Water Flow	Capacity	Min. Ambient Temp	GPM Adjustment= 100% Capacity
10%	x 1.020	x 0.99	26°F	x 1.01
20%	x 1.028	x 0.98	18°F	x 1.03
30%	x 1.036	x 0.98	8°F	x 1.07
40%	x 1.048	x 0.97	-7°F	x 1.11
50%	x 1.057	x 0.96	-29°F	x 1.16

**** A minimum of ten percent propylene glycol even in areas where there is no danger of freezing.**

Example: 30% glycol solution.

Maximum Flow Rate = 14.4 gpm x 1.036

System capacity x .98

Use Propylene Glycol Only

Important

If the outside temperature is expected to fall below freezing (32°F) in the area the Multiaqua chiller is to be installed; the installer must take the following precautions. Failure to do so will void the warranty.

To not engage in cold ambient mitigation will result in the failure of components such as the heat exchanger, compressor, piping, circulating pump, etc... and or property damage.

• Keep the liquid solution at a minimum of ten percent propylene glycol even in climates where there is no danger of freezing.

• The additional percentage amount of glycol recommended is dependent on the expected ambient temperatures and the solution makeup recommendation of the glycol manufacturer. Refer to the Glycol Solution Data table above.

• Ensure the system circulating pump is in a constant energized mode to keep a continuous circulation of liquid solution.

The Multiaqua chiller is a self-contained air-cooled condenser, coupled with an insulated brazed plate heat exchanger (evaporator). The system utilizes a scroll compressor to circulate refrigerant between the condenser and heat exchanger. The refrigerant is metered into the heat exchanger with a thermostatic expansion valve. Protecting the system are high and low pressure switches as well as a pump flow switch.

Liquid solution (water and propylene glycol; minimum 10 % is required) is circulated through the heat exchanger by an externally mounted pump. The liquid solution flows through the heat exchanger to the system supply piping and on to the air handlers.

Low ambient kits are available for operating ambient temperatures down to 0 degrees Fahrenheit. The low ambient kits consist of an ICM 325 (+) ICM (175) for all chillers.

MAC060-03-L Cooling Performance Data

MAC060 CAPACITIES with 0% Glycol										
LWT (°F)	ENTERING AIR TEMPERATURE (°F)									
	82		95		100		105		110	
	TONS	GPM	TONS	GPM	TONS	GPM	TONS	GPM	TONS	GPM
35	3.90	12.0	3.70	12.0	3.60	12.0	3.50	12.0	3.50	12.0
40	4.50		4.30		4.20		4.10			
42	4.80		4.60		4.50		4.30			
44	5.10		4.90		4.80		4.70			
45	5.30		5.10		5.00		4.80			
46	5.40		5.20		5.10		5.00			
48	5.80		5.60		5.40		5.30			
50	6.10		5.90		5.70		5.60			
55	7.00		6.70		6.40		6.30			
60	7.80		7.50		7.30		7.10			

MAC060 CAPACITIES with 10% Glycol										
LWT (°F)	ENTERING AIR TEMPERATURE (°F)									
	82		95		100		105		110	
	TONS	GPM	TONS	GPM	TONS	GPM	TONS	GPM	TONS	GPM
35	3.86	12.0	3.66	12.0	3.56	12.0	3.47	12.0	3.47	12.0
40	4.46		4.26		4.16		4.06			
42	4.75		4.55		4.46		4.26			
44	5.05		4.85		4.75		4.65			
45	5.25		5.05		4.95		4.75			
46	5.35		5.15		5.05		4.95			
48	5.74		5.54		5.35		5.25			
50	6.04		5.84		5.64		5.54			
55	6.93		6.63		6.34		6.24			
60	7.72		7.43		7.23		7.03			

MAC060 CAPACITIES with 20% Glycol										
LWT (°F)	ENTERING AIR TEMPERATURE (°F)									
	82		95		100		105		110	
	TONS	GPM	TONS	GPM	TONS	GPM	TONS	GPM	TONS	GPM
35	3.82	12.0	3.63	12.0	3.53	12.0	3.43	12.0	3.43	12.0
40	4.41		4.21		4.12		4.02			
42	4.70		4.51		4.41		4.21			
44	5.00		4.80		4.70		4.61			
45	5.19		5.00		4.90		4.70			
46	5.29		5.10		5.00		4.90			
48	5.68		5.49		5.29		5.19			
50	5.98		5.78		5.59		5.49			
55	6.86		6.57		6.27		6.17			
60	7.64		7.35		7.15		6.96			

These specifications are subject to change without notice.
Check www.multiaqua.com for the latest information.

MAC060-03-L Cooling Performance Data

MAC060 CAPACITIES with 30% Glycol										
LWT (°F)	ENTERING AIR TEMPERATURE (°F)									
	82		95		100		105		110	
	TONS	GPM	TONS	GPM	TONS	GPM	TONS	GPM	TONS	GPM
35	3.82	12.0	3.63	12.0	3.53	12.0	3.43	12.0	3.43	12.0
40	4.41		4.21		4.12		4.02		4.02	
42	4.70		4.51		4.41		4.21		4.31	
44	5.00		4.80		4.70		4.61		4.61	
45	5.19		5.00		4.90		4.70		4.70	
46	5.29		5.10		5.00		4.90		4.90	
48	5.68		5.49		5.29		5.19		5.19	
50	5.98		5.78		5.59		5.49		5.49	
55	6.86		6.57		6.27		6.17		6.08	
60	7.64		7.35		7.15		6.96		6.86	

MAC060 CAPACITIES with 40% Glycol										
LWT (°F)	ENTERING AIR TEMPERATURE (°F)									
	82		95		100		105		110	
	TONS	GPM	TONS	GPM	TONS	GPM	TONS	GPM	TONS	GPM
35	3.78	12.0	3.59	12.0	3.49	12.0	3.40	12.0	3.40	12.0
40	4.37		4.17		4.07		3.98		3.98	
42	4.66		4.46		4.37		4.17		4.27	
44	4.95		4.75		4.66		4.56		4.56	
45	5.14		4.95		4.85		4.66		4.66	
46	5.24		5.04		4.95		4.85		4.85	
48	5.63		5.43		5.24		5.14		5.14	
50	5.92		5.72		5.53		5.43		5.43	
55	6.79		6.50		6.21		6.11		6.01	
60	7.57		7.28		7.08		6.89		6.79	

MAC060 CAPACITIES with 50% Glycol										
LWT (°F)	ENTERING AIR TEMPERATURE (°F)									
	82		95		100		105		110	
	TONS	GPM	TONS	GPM	TONS	GPM	TONS	GPM	TONS	GPM
35	3.74	12.0	3.55	12.0	3.46	12.0	3.36	12.0	3.36	12.0
40	4.32		4.13		4.03		3.94		3.94	
42	4.61		4.42		4.32		4.13		4.22	
44	4.90		4.70		4.61		4.51		4.51	
45	5.09		4.90		4.80		4.61		4.61	
46	5.18		4.99		4.90		4.80		4.80	
48	5.57		5.38		5.18		5.09		5.09	
50	5.86		5.66		5.47		5.38		5.38	
55	6.72		6.43		6.14		6.05		5.95	
60	7.49		7.20		7.01		6.82		6.72	

These specifications are subject to change without notice.
Check www.multiaqua.com for the latest information.

MAC060-03-L Chiller Pump Curve

Pump Model Numbers
SSP-2 = 208/230/460-3-50/60
0.5 Horsepower

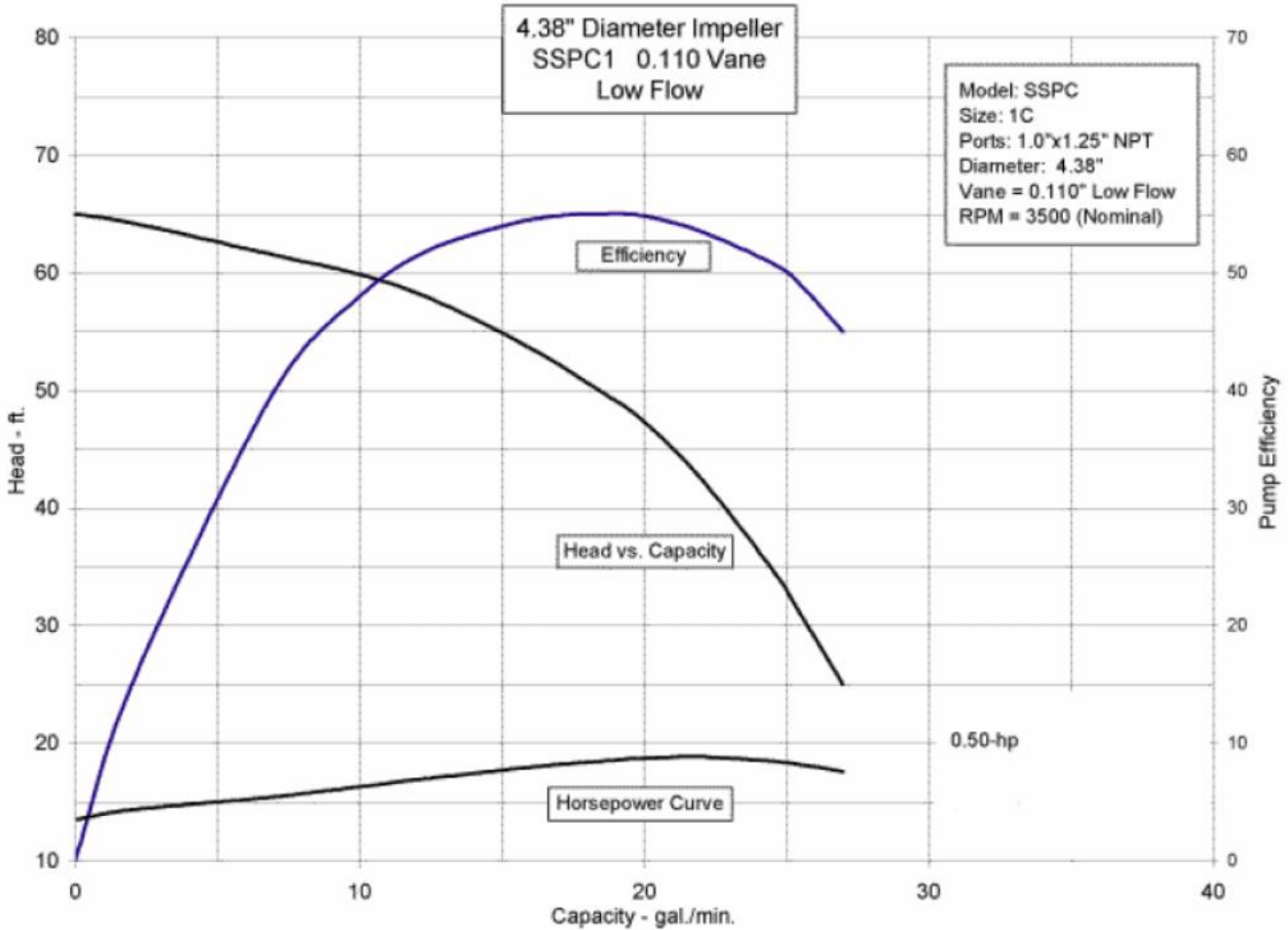

*These specifications are subject to change without notice.
 Check www.multiaqua.com for the latest information.*

MAC060-03-L Sound Data

MODEL #	MAC060-03-L
Fan Speed	dB @ 1 m
H	69

MAC060-03-L Wiring Diagram

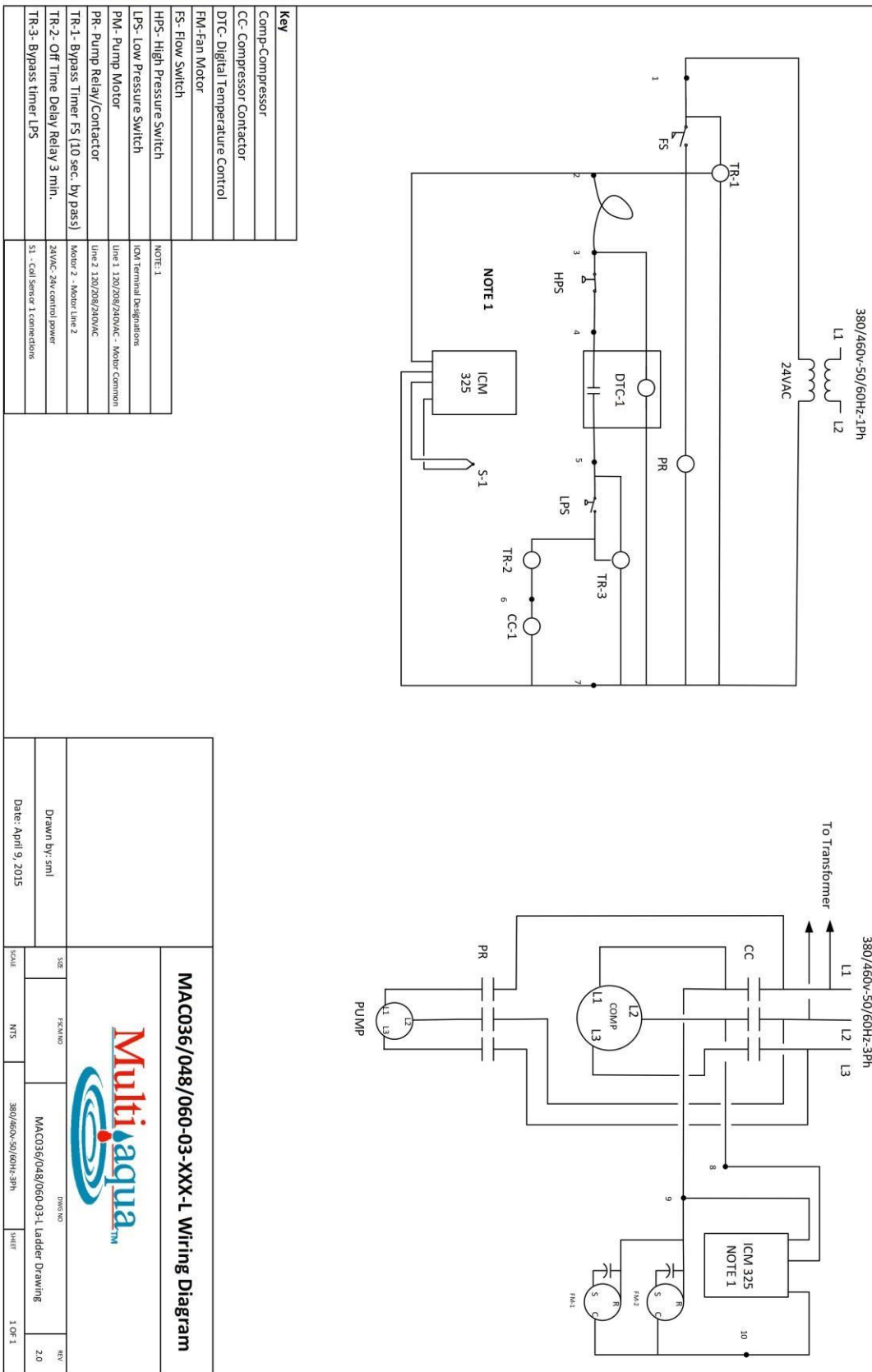

These specifications are subject to change without notice.
 Check www.multiaqua.com for the latest information.

MAC060-03-L Dimensional Drawing

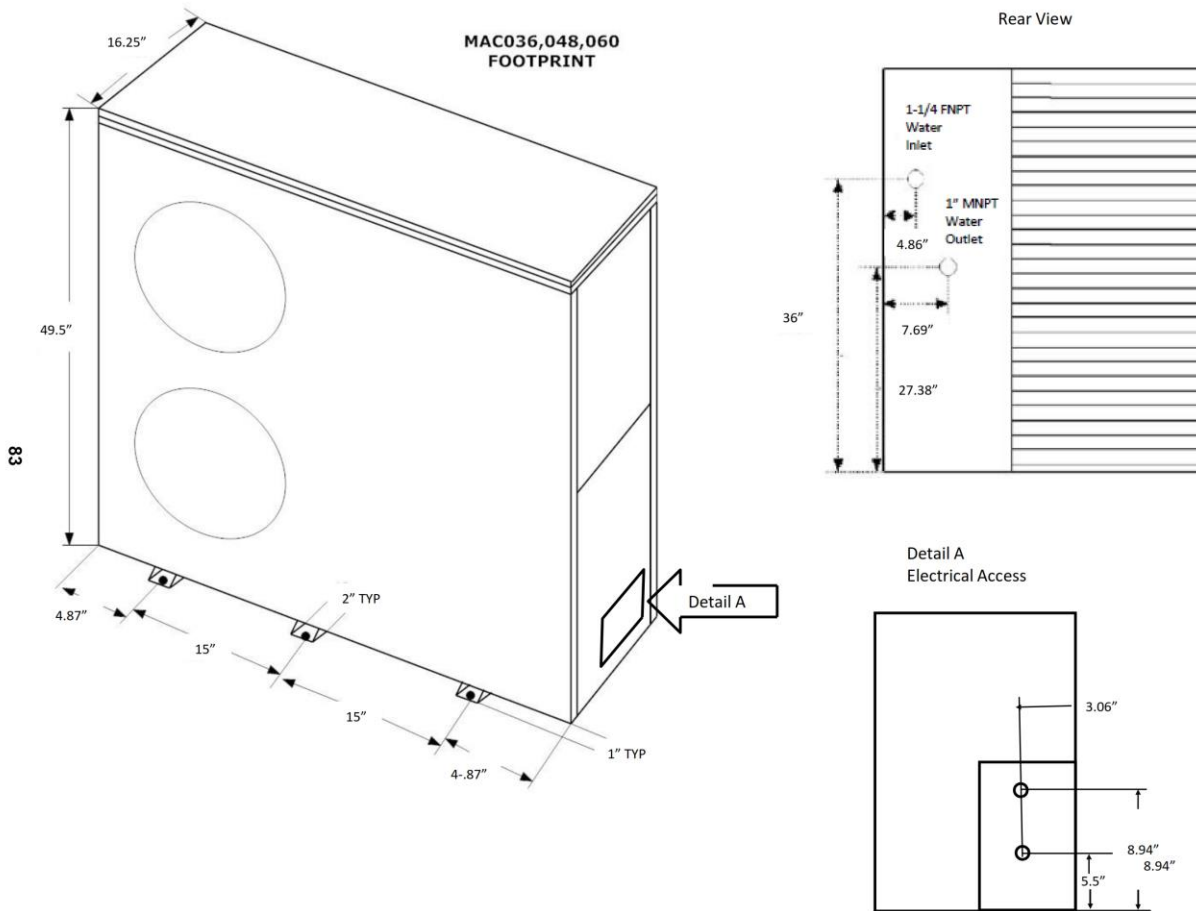

MAC036, 048, 060 CERTIFIED DRAWING

Revised 3/13/13 SL

Multiaqua Inc.
 306 Hagood Street
 Easley, SC 29640
 Ph: 864-850-8990
 Fax: 864-850-8995
www.multiaqua.com

For Technical Assistance:
 1-855-THNK-WTR (1-855-846-5987)

*These specifications are subject to change without notice.
 Check www.multiaqua.com for the latest information.*